



United Technologies  
turn to the experts 

## Package Rooftop Units – 50Hz



Quality Assurance  
Certificate Reg. No:  
04 100 950420



Subject to change without notice  
Manufacturing point: Jeddah, Saudi Arabia  
Nearest port of embarkation: Jeddah Islamic port  
Product classification: Commercial

Product Data Catalog

**50ZPM – 50Hz**

**Nominal Cooling Capacity 3.0 – 5.0 Tons**

**HFC R-410A Refrigerant**

The 50ZPM units are single side discharge rooftop cooling unit utilizing electric heat as an option. Units are pre-wired, pre-charged with R-410A refrigerant, and tested at the factory. These units can be placed on the side of a building or can be placed on a roof without roof curbs. Each unit is designed to occupy a minimal space. Piping and drain connections are readily accessible.

The 50ZPM unit is a packaged air conditioner manufactured for housing, residential, and light commercial applications. The 50ZPM unit design is the result of our firm commitment to the development of the finest air conditioners that modern technology can offer.

# TABLE OF CONTENTS

Features / Benefits.....	2
Model No. Nomenclature .....	3
AHRI Capacity Ratings / Sound Power Level.....	4
Physical Data .....	5
Base Unit Dimensions .....	7
Selection Procedure .....	8
Cooling Capacities .....	9
Performance & Accessories .....	12
Electrical Data.....	13
Typical Wiring Schematic .....	14
Typical Installation .....	15
Application Data / Operating Sequence .....	16
Guide Specifications .....	17

## FEATURES / BENEFITS

**Factory-Assembled Package** is a compact, fully self-contained, electric cooling unit with horizontal supply and return ducts. The 50ZPM units are available in three standard cooling sizes to meet residential and light commercial requirements. Unit installs easily on a ground level pad.

**Easy to Install** 50ZPM units are small, compact, and easy to handle. Every 50ZPM unit has an identical 32x51-in. (813x1295 mm) footprint. The concise design uses less sheet metal and makes the 50ZPM units lighter than other units. The unit can be easily positioned on the job site with the hand holds built into the unit base-pan.

**Aerodynamic Fan Blade Design** reduces the overall sound power level to as low as 76.3dBA.

**Service Access** makes installation and maintenance quicker and easier. The 50ZPM units are designed to be serviced from both the side and front. The design allows easy access for installation and maintenance procedures on the unit. Routine maintenance task time such as coil cleaning is minimized with the multiple access side panels.

**Durable Pre-Painted Galvanized Steel Cabinet** protects against harsh weather with watertight construction and corrosion resistant finish. The paint treatment process ensures quality protection against the elements. A compact, low-profile design utilizes a louvered coil enclosure for protection against vandalism and hail damage.

**Indoor Air Quality** is designed into the 50ZPM units. A sloped drain pan minimizes the amount of standing water inside the unit, which limits mold and mildew growth. The drain pan is made of a rust-proof material and will not deteriorate or release foreign matter into the airstream.

**Refrigerant System** is designed to provide dependability. Liquid refrigerant filter driers are used to promote clean, unrestricted operation. Each unit leaves the factory with a full refrigerant charge. Refrigerant service connections make checking operating pressures easier.

**Durable, Dependable, Compressors** are designed for high efficiency. Each compressor is hermetically sealed against contamination to help promote longer life and dependable operation. Vibration isolation provides quiet operation. Compressors have internal overcurrent protection.

**Direct-Drive Multispeed, Blower Motor** is standard on all models. It's high efficiency design ensures high performance with most duct systems.

**Accessory Electric Heaters** are available in a variety of sizes for the 50ZPM. These heaters are comprised of a separate heater module mounted on the blower inlet and remote mounted controls located in the unit control box. Single point electrical connections are available for powering both the heater and the unit.

# MODEL NUMBER NOMENCLATURE – 50ZPM – R410A SERIES

1	2	3	4	5	6	7	8	9	10	11	12	13	14	15	16	17	18
5	0	Z	P	M	-	3	6	A	3	A	1	A	0	A	0	A	S

**Unit Heat Type**  
50 = Cooling /  
Electric Heat RTU

**Model Series**  
ZPM = High Ambient Desert Master  
Series with R-410A Refrigerant

**Factory Use**  
- = Factory Assigned

**Nominal Capacity**  
36 = 3.0 Tons  
48 = 4.0 Tons  
60 = 5.0 Tons

**Sensor Options**  
A = None

**Power Supply (V/Ph/Hz)**  
9 = 400/3/50

**Reference**  
S = Standard  
B = Bahrain

**Electrical Options**  
A = None  
C = Capacitor Bank

**Service Options**  
0 = None

**IAQ Options**  
A = None

**Base Unit Controls**  
0 = Electromechanical Controller

**Design Revision**  
A = Factory Assigned

**Indoor Fan Motor Options**  
1 = Standard

**Coil Fins Options (Outdoor - Indoor)**  
A = Al/Cu - Al/Cu  
B = Pre-coat Al/Cu - Al/Cu  
C = Cu/Cu - Cu/Cu  
E = Cu/Cu - Al/Cu

# AHRI CAPACITY RATING

50ZPM Unit	Nominal Capacity (Tons)	Gross Cooling Capacity (BTU/hr)	Net Cooling Capacity (BTU/hr)	Net Cooling Capacity (Watt)	EER	Standard CFM	Standard m3/hr	Standard L/S
36	3.0	36785	36785	10554	11.6	1200	2038	566
48	4.0	49399	48000	14072	11.6	1600	2717	755
60	5.0	57228	56000	16417	11.6	1650	2802	779

**Legend:**

AHRI - Air Conditioning, Heating and Refrigeration Institute  
 EER - Energy Efficiency Ratio

**Notes:**

1. Rated in accordance with AHRI Standards 340/360.
2. Rating are based on:
  - Cooling Standard: 80 F db, 67 wb indoor entering-air temperature and 95 F db air entering outdoor unit.

## SOUND POWER LEVELS

50ZPM Unit	Unit Sound (dB) - Typical Octave Band Spectrum								
	Rating (dBA)	63	125	250	500	1000	2000	4000	8000
36	76.3	69.0	69.5	72.5	72.5	71.0	69.0	68.0	58.0
48	76.8	69.0	68.5	69.0	74.0	73.0	69.0	65.0	59.0
60	78.9	64.0	66.0	69.0	75.0	75.0	72.5	66.5	57.0

**Legend:**

dBA - Decibel A-Weighted

# PHYSICAL DATA - ENGLISH

<b>Unit 50ZPM</b>	<b>36</b>	<b>48</b>	<b>60</b>
Unit Size (Nominal Ton)	3.0	4.0	5.0
Unit Dimensions - in	50.98 x 31.99 x 34.61	50.98 x 31.99 x 38.62	50.98 x 31.99 x 46.62
Unit Operation Weight - LBS	279	305	352
<b>Refrigeration System</b>			
Compressor No.# / Type	1 / Reciprocating	1 / Scroll	
Refrigerant Type	Puron ® R410A		
Circuits No.#	1		
Charge - LBS	5.81	5.83	7.38
Metering Device / ORIFIC OD (in)	Piston / 0.067	Piston / 0.082	TXV / N.A
Filter Drier Qty	1		
High Pressure Switch (Trip ±15/ Reset±25) - PSIG	650 / 420		
Low Pressure Switch (Trip ±5/ Reset±5) - PSIG	54 / 117		
<b>Condenser Coil <sup>(1)</sup></b>			
Coil Type	7mm Helical Grooved Copper Tube, 0.74" Aluminum LSW Fins		
Standard Coil Material	Cu/Al		
Rows / Fins (FPI)	2 / 20		
Face Area (ft <sup>2</sup> )	9.1	10.2	13.0
Coil Test Pressure (PSIG)	450		
<b>Condenser Fan &amp; Motor</b>			
Approx. Air Flow Rate (CFM)	3350	3400	3700
Quantity	1		
Diameter (in) / No. of Blades	20 / 3		20 / 4
Motor Type	Induction Motor - Totally Enclosed		
Motor HP - RPM	1/3 - 1460		
<b>Evaporator Coil <sup>(2)</sup></b>			
Coil Type	3/8" Helical Grooved Copper Tube, 0.75" Aluminum LSW Fins		
Standard Coil Material	Cu/Al		
Rows / FPI	3 / 12		
Face Area (ft <sup>2</sup> )	4.3	4.9	6.1
Coil Test Pressure (PSIG)	350		
Drain Pan Connection Size (in)	3 / 4		
Return Air Filter Qty / Size (in) - Recommended <sup>(3)</sup>	1 / 24 x 30 x 1		1 / 24 x 36 x 1
<b>Evaporator Fan and Motor Section</b>			
Fan Quantity	1		
Fan Size (Diam. x L) (in)	11.0 x 9.0		12.0 x 10.5
Fan Type	Centrifugal - Forward Blade		
Drive Type	Direct Drive		
Motor Type	Electronically Commutated (ECM)		
Indoor Motor Factory Speed Setting	Medium		Low
Motor Quantity	1		
Maximum HP - Maximum Watt	1/2 - 530	3/4 - 780	1 - 1050
FLA	4.1	6.0	7.6
Efficiency %	78.5	80.0	79.0
No. Of Taps	3 - [1 (Low) - 2 (Medium) - 3 (High)]		
Tap Torque (OZ Ft) [L - M - H]	26.20 - 30.27 - 34.98	43.06 - 45.88 - 58.12	42.98 - 45.80 - 54.90
% of Full Output @ Tap [L - M - H]	65.49 - 75.69 - 87.45	71.76 - 76.47 - 96.86	53.73 - 57.25 - 68.63
Motor OFF- Delay (sec.) @ Tap [L - M - H]	60 - 30 - 0		
Nominal Air Flow Rate (CFM)	1200	1600	1650
External Static Pressure (In.W.G)	Up to 1.0"		
RPM Range	600 - 1200		
Motor Frame Size	NEMA Size - 48 Motor		

(1) Condenser Copper Coils : 21 FPI

(2) Evaporator Copper Coils : 13 FPI

(3) Field Supplied - Field Installed Filter

# PHYSICAL DATA - SI

<b>Unit 50ZPM</b>	36	48	60
Unit Size (Nominal Ton)	3.0	4.0	5.0
Unit Dimensions - mm	1295.0 x 812.5 x 879	1295.0 x 812.5 x 981	1295.0 x 812.5 x 1184
Unit Operation Weight - kg	127	139	160
<b>Refrigeration System</b>			
Compressor No.# / Type	1 / Reciprocating	1 / Scroll	
Refrigerant Type	Puron ® R410A		
Circuits No.#	1		
Charge - kg	2.64		3.35
Metering Device / ORIFIC OD(mm)	Piston / 1.70	Piston / 2.08	TXV / N.A
Filter Drier Qty	1		
High Pressure Switch (Trip ±1/ Reset±1.7)- kPaG	44 / 29		
Low Pressure Switch (Trip ±0.3/ Reset±0.3)- kPaG	4 / 8		
<b>Condenser Coil <sup>(1)</sup></b>			
Coil Type	7mm Helical Grooved Copper Tube, 0.74" Aluminum LSW Fins		
Standard Coil Material	Cu/Al		
Rows / Fins (FPI)	2 / 20		
Face Area (m <sup>2</sup> )	0.85	0.95	1.21
Coil Test Pressure (bar)	31		
<b>Condenser Fan &amp; Motor</b>			
Approx. Air Flow Rate (m <sup>3</sup> /hr)	5690	5773	6283
Quantity	1		
Diameter (mm) / No. of Blades	508 / 3		508 / 4
Motor Type	Induction Motor - Totally Enclosed		
Motor HP - RPS	1/3 - 24		
<b>Evaporator Coil <sup>(2)</sup></b>			
Coil Type	3/8" Helical Grooved Copper Tube, 0.75" Aluminum LSW Fins		
Standard Coil Material	Cu/Al		
Rows / FPI	3 / 12		
Face Area (m <sup>2</sup> )	0.40	0.46	0.57
Coil Test Pressure (bar)	23.8		
Drain Pan Connection Size (mm)	19		
Return Air Filter Qty / Size (mm) - Recommended <sup>(3)</sup>	1 / 610 x 762 x 25		1 / 610 x 914 x 25
<b>Evaporator Fan and Motor Section</b>			
Fan Quantity	1		
Fan Size (Diam. x L) (in)	11.0 x 9.0		12.0 x 10.5
Fan Type	Centrifugal - Forward Blade		
Drive Type	Direct Drive		
Motor Type	Electronically Commutated (ECM)		
Indoor Motor Factory Speed Setting	Medium		Low
Motor Quantity	1		
Maximum HP - Maximum Watt	1/2 - 530	3/4 - 780	1 - 1050
FLA	4.1	6.0	7.6
Efficiency %	78.5	80.0	79.0
No. Of Taps	3 - [1 (Low) - 2 (Medium) - 3 (High)]		
Tap Torque (OZ Ft) [L - M - H]	26.20 - 30.27 - 34.98	43.06 - 45.88 - 58.12	42.98 - 45.80 - 54.90
% of Full Output @ Tap [L - M - H]	65.49 - 75.69 - 87.45	71.76 - 76.47 - 96.86	53.73 - 57.25 - 68.63
Motor OFF- Delay (sec.) @ Tap [L - M - H]	60 - 30 - 0		
Nominal Air Flow Rate (CFM)	1200	1600	1650
External Static Pressure (In.W.G)	Up to 1.0"		
RPM Range	600 - 1200		
Motor Frame Size	NEMA Size - 48 Motor		

(1) Condenser Copper Coils : 21 FPI

(2) Evaporator Copper Coils : 13 FPI

(3) Field Supplied - Field Installed Filter

# BASE UNIT DIMENSIONS – 50ZPM Series

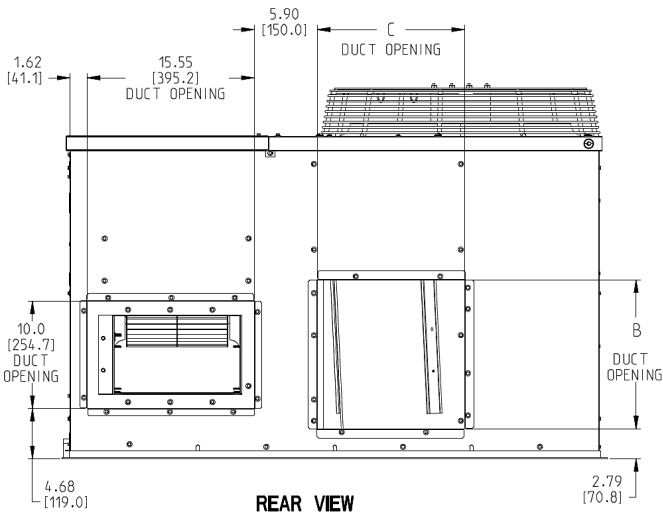

REAR VIEW

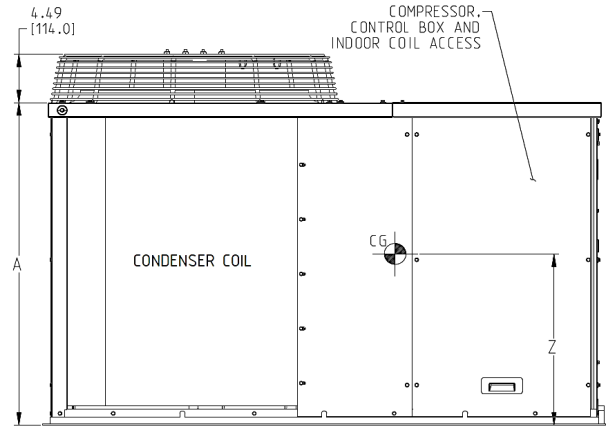

FRONT VIEW

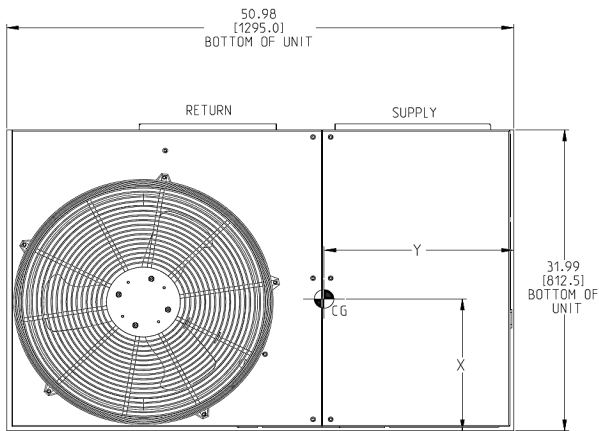

TOP VIEW

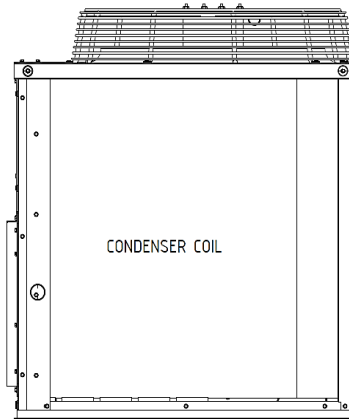

LEFT SIDE VIEW

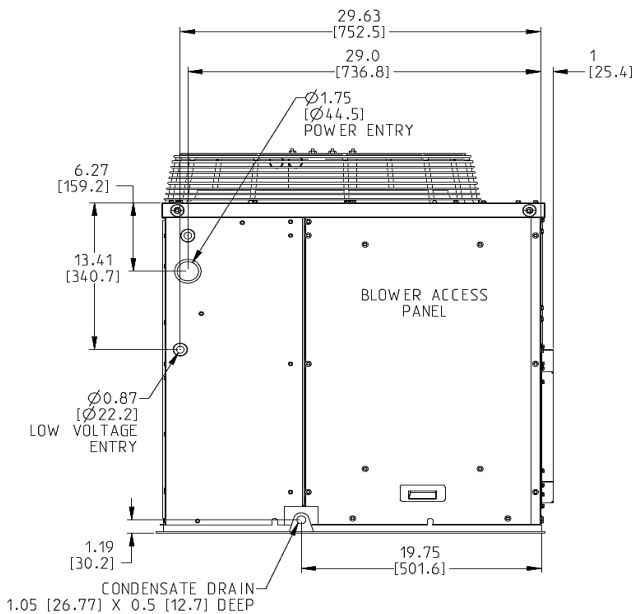

RIGHT SIDE VIEW

NEC REQUIRED CLEARANCE	INCHES [MM]
BETWEEN UNITS, POWER ENTRY SIDE.....	42.0 [1067]
UNIT AND UNGROUNDED SURFACES, POWER ENTRY SIDE.....	36.0 [914]
UNIT AND BLOCK OR CONCRETE WALLS AND OTHER GROUNDED SURFACES, POWER ENTRY SIDE.....	42.0 [1067]
SIDE OF UNIT WITH DUCT OPENING.....	0

REQUIRED CLEARANCE FOR SERVICING	INCHES [MM]
TOP OF UNIT.....	36.0 [914]
SIDE OF UNIT OPPOSITE DUCT OPENINGS.....	30.0 [762]
SIDE OF UNIT WITH POWER ENTRY..... (EXCEPT FOR NEC REQUIREMENTS)	30.0 [762]

NEC - NATIONAL ELECTRIC CODE

NOTE:  
 1. CLEARANCE MUST BE MAINTAINED TO PREVENT RECIRCULATION OF AIR FROM OUTDOOR FAN DISCHARGE. A REMOVAL FENCE OR BARRICADE REQUIRES NO CLEARANCE.  
 2. DIMENSIONS ARE IN INCHES. DIMENSIONS IN [ ] ARE IN MILLIMETERS.

Unit 50ZPM	Unit Weight		Unit Height	Duct Opening			Center of Gravity (mm)		
	LBS.	KG.	A	B	C	X	Y	Z	
36	279	127	30.12 [765]	14.0 [357.7]	13.7 [348]	14 [356]	19 [483]	14.0 [356]	
48	305	139	34.13 [867]	19.9 [506.14]	13.9 [354]	14 [356]	19 [483]	16.0 [406]	
60	352	160	42.13 [1070]	19.9 [506.14]	13.9 [354]	14 [356]	19 [483]	19.8 [503]	

- Center Of Gravity

# SELECTION PROCEDURE

## A. DETERMINE COOLING AND HEATING REQUIREMENTS AT DESIGN CONDITIONS.

Given:

- Required Cooling Capacity (TC) . . . . . 34,000 Btuh
- Sensible Heat Capacity (SHC) . . . . . 25,000 Btuh
- Required Heating Capacity . . . . . 15,000 Btuh
- Outdoor Entering-Air Temperature . . . . . 95° F (35° C)
- Indoor Entering-Air Temperature . . . 80° F edb (26.7° C); 67° F (19.4° C) ewb
- Indoor-Air Quantity . . . . . 1200 CFM
- External Static Pressure . . . . . 0.10 in. wg.
- Electrical Characteristics (V- Ph-Hz) . . . . . 400- 3- 50

## B. SELECT UNIT BASED ON REQUIRED COOLING CAPACITY. (Values given are indicative only not actual)

Enter Cooling Capacities table at condenser entering temperature of 95°F (35° C), indoor air entering at 1200 CFM and 67° F (19.4° C) ewb. The 50ZPM36 unit provides a total cooling capacity of 36,785 Btuh and a sensible heat capacity of 27,454 Btuh. For indoor- air temperature other than 80° F (26.7° C) edb, calculate sensible heat capacity correction, as required, using the formula found following the Cooling Capacities tables.

## C. SELECT ELECTRIC HEAT.

The required heating capacity is 15,000 Btuh (given). Determine the electric heat capacity in kW.

**15,000 Btuh = 3.8 kW of heat required**  
**3414 Btuh/kW**

Enter the Accessory Electric Heater table, single- phase, 50ZPM unit. The 4.59- kW heater at 230v most closely satisfies the heating required.

4.59 kW x 3414 Btuh/kW = 15,670 Btuh

## D. DETERMINE FAN SPEED AND POWER REQUIREMENTS AT DESIGN CONDITIONS.

Before entering the air delivery tables, calculate the total static pressure required. From the given, Filter Pressure Drop table and the Accessory Electric Heat Pressure Drop table find:

- External static pressure 0.10 in. wg.
- Filter 0.07 in. wg. (Carrier Recommended) Electric Heat 0.042 in. wg.
- Total static pressure 0.212 in. wg.

Enter the table for Coil Air Delivery. At 0.212 in. wg. external static pressure and medium speed, the motor delivers 1233 CFM.

Note:

1. Cooling capacities are gross and do not include deductions for indoor fan motor heat.
2. Filter static pressure depends on your filter selection.



# COOLING CAPACITIES

## 50ZPM - 36 - English

Temp (F) Air Entering Condenser (Edb)		Evaporator Air - CFM/BPF											
		1050 / 0.257				1200 / 0.268				1350 / 0.287			
		Evaporator Air - EWB (F)											
		57	62	67	72	57	62	67	72	57	62	67	72
75	TC	35,384	36,692	40,783	45,114	16,166	37,745	41,860	46,261	38,161	38,465	42,453	46,917
	SHC	35,282	32,716	28,114	23,105	12,725	35,287	30,220	24,398	38,052	36,965	31,610	25,282
	kW	1.96	1.97	2.02	2.06	1.78	2.06	2.11	2.14	2.13	2.14	2.17	2.21
85	TC	33,725	15,740	38,418	42,566	35,332	35,555	39,325	43,530	36,287	36,594	39,893	44,100
	SHC	33,629	11,294	27,247	22,249	35,231	34,285	29,316	23,492	36,184	35,623	30,709	24,358
	kW	2.13	1.81	2.19	2.23	2.23	2.23	2.27	2.31	2.31	2.31	2.34	2.38
95	TC	32,014	32,309	36,049	39,907	33,470	33,539	<b>36,785</b>	40,732	34,346	34,624	37,248	41,228
	SHC	31,922	30,532	26,299	21,336	33,374	33,345	<b>28,385</b>	22,556	34,248	33,709	29,709	23,403
	kW	2.30	2.30	2.35	2.40	2.40	2.40	<b>2.44</b>	2.49	2.47	2.48	2.51	2.56
105	TC	30,222	30,265	33,502	37,149	31,540	31,585	34,127	37,808	32,340	32,381	34,430	38,232
	SHC	30,135	29,477	25,388	20,412	31,450	31,495	27,401	21,599	32,248	32,289	28,798	22,406
	kW	2.43	2.44	2.49	2.54	2.53	2.54	2.58	2.63	2.61	2.61	2.64	2.70
115	TC	28,331	28,596	30,943	34,265	29,492	29,538	31,401	34,785	30,211	30,247	31,706	35,139
	SHC	28,251	27,909	24,340	19,389	29,408	29,454	26,208	20,507	30,125	30,161	27,328	21,276
	kW	2.53	2.54	2.59	2.65	2.64	2.64	2.67	2.73	2.71	2.71	2.74	2.80
118.4	TC	25,606	25,836	27,784	30,767	26,612	26,645	28,168	31,198	27,254	27,286	28,460	31,505
	SHC	25,534	25,196	22,182	17,615	26,537	26,570	23,817	18,621	27,177	27,210	24,934	19,350
	kW	2.59	2.59	2.64	2.71	2.69	2.69	2.72	2.79	2.77	2.77	2.79	2.86
125	TC	20,121	20,151	21,599	23,896	20,895	20,934	21,864	24,206	21,435	21,459	22,139	24,465
	SHC	20,064	20,061	17,735	14,033	20,837	20,822	18,992	14,810	21,375	21,360	19,937	15,418
	kW	2.69	2.69	2.74	2.82	2.80	2.80	2.83	2.90	2.88	2.88	2.90	2.98

## 50ZPM - 36 - SI

Temp (F) Air Entering Condenser (Edb)		Evaporator Air - (L/s)/BPF											
		496 / 0.257'				566 / 0.268				637 / 0.287			
		Evaporator Air - EWB (C)											
		14	17	19	22	14	17	19	22	14	17	19	22
24	TC	10.4	10.8	12.0	13.2	4.7	11.1	12.3	13.6	11.2	11.3	12.4	13.8
	SHC	10.3	9.6	8.2	6.8	3.7	10.3	8.9	7.2	11.2	10.8	9.3	7.4
	kW	1.96	1.97	2.02	2.06	1.78	2.06	2.11	2.14	2.13	2.14	2.17	2.21
29	TC	9.9	4.6	11.3	12.5	10.4	10.4	11.5	12.8	10.6	10.7	11.7	12.9
	SHC	9.9	3.3	8.0	6.5	10.3	10.0	8.6	6.9	10.6	10.4	9.0	7.1
	kW	2.13	1.81	2.19	2.23	2.23	2.23	2.27	2.31	2.31	2.31	2.34	2.38
35	TC	9.4	9.5	10.6	11.7	9.8	9.8	<b>10.8</b>	11.9	10.1	10.1	10.9	12.1
	SHC	9.4	8.9	7.7	6.3	9.8	9.8	<b>8.3</b>	6.6	10.0	9.9	8.7	6.9
	kW	2.30	2.30	2.35	2.40	2.40	2.40	<b>2.44</b>	2.49	2.47	2.48	2.51	2.56
40.6	TC	8.9	8.9	9.8	10.9	9.2	9.3	10.0	11.1	9.5	9.5	10.1	11.2
	SHC	8.8	8.6	7.4	6.0	9.2	9.2	8.0	6.3	9.5	9.5	8.4	6.6
	kW	2.43	2.44	2.49	2.54	2.53	2.54	2.58	2.63	2.61	2.61	2.64	2.70
46	TC	8.3	8.4	9.1	10.0	8.6	8.7	9.2	10.2	8.9	8.9	9.3	10.3
	SHC	8.3	8.2	7.1	5.7	8.6	8.6	7.7	6.0	8.8	8.8	8.0	6.2
	kW	2.53	2.54	2.59	2.65	2.64	2.64	2.67	2.73	2.71	2.71	2.74	2.80
48	TC	7.5	7.6	8.1	9.0	7.8	7.8	8.3	9.1	8.0	8.0	8.3	9.2
	SHC	7.5	7.4	6.5	5.2	7.8	7.8	7.0	5.5	8.0	8.0	7.3	5.7
	kW	2.59	2.59	2.64	2.71	2.69	2.69	2.72	2.79	2.77	2.77	2.79	2.86
52	TC	5.9	5.9	6.3	7.0	6.1	6.1	6.4	7.1	6.3	6.3	6.5	7.2
	SHC	5.9	5.9	5.2	4.1	6.1	6.1	5.6	4.3	6.3	6.3	5.8	4.5
	kW	2.69	2.69	2.74	2.82	2.80	2.80	2.83	2.90	2.88	2.88	2.90	2.98

### LEGEND

BPF — Bypass Factor  
 Edb — Entering Dry-Bulb  
 Ewb — Entering Wet-Bulb  
 SHC — Sensible Heat Capacity (1000 Btuh) - Gross  
 Ldb — Leaving Dry-Bulb  
 Lwb — Leaving Wet-Bulb  
 TC — Total Capacity (1000 Btuh) - Gross  
 kW — Compressor Motor Power Input

**Bold, Italics** - Standard Ratings

### Notes:

- Direct interpolation is permissible. Do not extrapolate.
- The following formulas may be used.

$$t_{ldb} = t_{edb} - \frac{\text{sensible capacity (Btuh)}}{1.10 \times \text{cfm}} \quad \text{hlwb} = \text{hewb} - \frac{\text{total capacity (Btuh)}}{4.5 \times \text{cfm}}$$

t<sub>lwb</sub> = Wet-bulb temperature corresponding to enthalpy of air leaving evaporator coil (hlwb).

h<sub>ewb</sub> = Enthalpy of air entering evaporator coil.

- The SHC is based on 80 F edb temperature of air entering evaporator coil.

- Below 80 F edb, subtract (corr factor x cfm) from SHC.

- Above 80 F edb, add (corr factor x cfm) to SHC.

ENTERING AIR DRY-BULB TEMP (F)						
BF	79	78	77	76	75	under 75
	81	82	83	84	85	over 85
Correction Factor						
0.05	1.04	2.07	3.11	4.14	5.18	Use formula shown*
0.10	0.98	1.96	2.94	3.92	4.90	
0.20	0.87	1.74	2.62	3.49	4.36	
0.30	0.76	1.53	2.29	3.05	3.82	

- Interpolation is permissible.

\*Correction Factor = 1.10 x (1 - BF) x (edb - 80).

- Cooling capacities are gross and do not include deductions for indoor fan motor heat.

# COOLING CAPACITIES (Continued)

50ZPM - 48 - English

Temp (F) Air Entering Condenser (Edb)		Evaporator Air - CFM/BPF											
		1400 / 0.219				1600 / 0.245				1750 / 0.265			
		Evaporator Air - EWB (F)											
		57	62	67	72	57	62	67	72	57	62	67	72
75	TC	47,178	49,302	53,732	58,112	49,058	50,495	54,768	59,212	50,719	51,593	55,873	60,337
	SHC	47,065	43,291	36,360	29,428	48,941	46,200	38,393	30,654	50,599	48,372	40,320	31,991
	kW	2.57	2.60	2.62	2.64	2.63	2.64	2.66	2.68	2.72	2.73	2.74	2.77
85	TC	45,373	46,999	51,220	55,500	47,142	48,023	52,171	56,492	48,717	49,112	53,216	57,560
	SHC	45,265	42,641	35,486	28,506	47,029	45,083	37,521	29,757	48,603	47,171	39,442	31,083
	kW	2.87	2.89	2.91	2.93	2.92	2.93	2.94	2.97	3.02	3.02	3.03	3.06
95	TC	42,752	43,466	48,528	52,788	44,604	44,836	<b>49,399</b>	53,673	46,301	46,392	50,402	54,658
	SHC	42,650	41,123	34,504	27,586	44,498	43,667	<b>36,563</b>	28,803	46,192	45,868	38,524	30,124
	kW	3.15	3.16	3.22	3.24	3.21	3.22	<b>3.26</b>	3.28	3.32	3.32	3.34	3.37
105	TC	41,154	41,164	46,163	51,246	42,938	42,951	47,182	52,217	44,562	44,549	48,208	53,272
	SHC	41,312	41,260	34,740	27,619	43,102	42,941	37,024	28,942	44,730	44,718	39,110	30,273
	kW	3.45	3.45	3.53	3.57	3.51	3.51	3.58	3.61	3.62	3.62	3.67	3.70
115	TC	38,134	38,136	42,073	47,520	39,855	39,870	42,972	48,353	41,446	41,434	43,964	49,321
	SHC	37,979	37,978	33,182	26,273	39,693	39,708	35,503	27,639	41,280	41,269	37,578	29,071
	kW	3.80	3.80	3.87	3.95	3.86	3.87	3.92	3.98	3.97	3.97	4.02	4.07
118.4	TC	36,898	36,906	40,435	46,005	38,608	38,597	41,323	46,803	40,157	40,146	42,230	47,749
	SHC	36,748	36,738	32,598	25,770	38,451	38,441	34,941	27,149	39,997	39,986	36,985	28,590
	kW	3.95	3.95	4.01	4.11	4.01	4.01	4.06	4.14	4.12	4.12	4.16	4.23
125	TC	33,218	33,222	35,808	41,326	34,778	34,768	36,489	42,054	36,238	36,227	37,469	42,913
	SHC	33,139	33,134	30,253	23,843	34,696	34,686	32,436	25,181	36,154	36,143	34,469	26,595
	kW	4.22	4.21	4.27	4.39	4.29	4.29	4.32	4.43	4.40	4.40	4.42	4.52

50ZPM - 48 - SI

Temp (F) Air Entering Condenser (Edb)		Evaporator Air - (L/s)/BPF											
		661 / 0.219				755 / 0.245				826 / 0.265			
		Evaporator Air - EWB (C)											
		14	17	19	22	14	17	19	22	14	17	19	22
24	TC	13.8	14.4	15.7	17.0	14.4	14.8	16.1	17.4	14.9	15.1	16.4	17.7
	SHC	13.8	12.7	10.7	8.6	14.3	13.5	11.3	9.0	14.8	14.2	11.8	9.4
	kW	2.57	2.60	2.62	2.64	2.63	2.64	2.66	2.68	2.72	2.73	2.74	2.77
29	TC	13.3	13.8	15.0	16.3	13.8	14.1	15.3	16.6	14.3	14.4	15.6	16.9
	SHC	13.3	12.5	10.4	8.4	13.8	13.2	11.0	8.7	14.2	13.8	11.6	9.1
	kW	2.87	2.89	2.91	2.93	2.92	2.93	2.94	2.97	3.02	3.02	3.03	3.06
35	TC	12.5	12.7	14.2	15.5	13.1	13.1	<b>14.5</b>	15.7	13.6	13.6	14.8	16.0
	SHC	12.5	12.1	10.1	8.1	13.0	12.8	<b>10.7</b>	8.4	13.5	13.4	11.3	8.8
	kW	3.15	3.16	3.22	3.24	3.21	3.22	<b>3.26</b>	3.28	3.32	3.32	3.34	3.37
40.6	TC	12.1	12.1	13.5	15.0	12.6	12.6	13.8	15.3	13.1	13.1	14.1	15.6
	SHC	12.1	12.1	10.2	8.1	12.6	12.6	10.9	8.5	13.1	13.1	11.5	8.9
	kW	3.45	3.45	3.53	3.57	3.51	3.51	3.58	3.61	3.62	3.62	3.67	3.70
46	TC	11.2	11.2	12.3	13.9	11.7	11.7	12.6	14.2	12.1	12.1	12.9	14.5
	SHC	11.1	11.1	9.7	7.7	11.6	11.6	10.4	8.1	12.1	12.1	11.0	8.5
	kW	3.80	3.80	3.87	3.95	3.86	3.87	3.92	3.98	3.97	3.97	4.02	4.07
48	TC	10.8	10.8	11.9	13.5	11.3	11.3	12.1	13.7	11.8	11.8	12.4	14.0
	SHC	10.8	10.8	9.6	7.6	11.3	11.3	10.2	8.0	11.7	11.7	10.8	8.4
	kW	3.95	3.95	4.01	4.11	4.01	4.01	4.06	4.14	4.12	4.12	4.16	4.23
52	TC	9.7	9.7	10.5	12.1	10.2	10.2	10.7	12.3	10.6	10.6	11.0	12.6
	SHC	9.7	9.7	8.9	7.0	10.2	10.2	9.5	7.4	10.6	10.6	10.1	7.8
	kW	4.22	4.21	4.27	4.39	4.29	4.29	4.32	4.43	4.40	4.40	4.42	4.52

**LEGEND**

- BPF — Bypass Factor
- Edb — Entering Dry-Bulb
- Ewb — Entering Wet-Bulb
- SHC — Sensible Heat Capacity (1000 Btuh) - Gross
- TC — Total Capacity (1000 Btuh) - Gross
- kW — Compressor Motor Power Input
- Ldb — Leaving Dry-Bulb
- Lwb — Leaving Wet-Bulb

**Bold, Italics** - Standard Ratings

**Notes:**

1. Direct interpolation is permissible. Do not extrapolate.
2. The following formulas may be used.

$$t_{ldb} = t_{edb} - \frac{\text{sensible capacity (Btuh)}}{1.10 \times \text{cfm}} \quad \text{hlwb} = \text{hewb} - \frac{\text{total capacity (Btuh)}}{4.5 \times \text{cfm}}$$

t<sub>lwb</sub> = Wet-bulb temperature corresponding to enthalpy of air leaving evaporator coil (hlwb).

h<sub>ewb</sub> = Enthalpy of air entering evaporator coil.

3. The SHC is based on 80 F edb temperature of air entering evaporator coil.

- Below 80 F edb, subtract (corr factor x cfm) from SHC. - Above 80 F edb, add (corr factor x cfm) to SHC.

ENTERING AIR DRY-BULB TEMP (F)						
BF	79	78	77	76	75	under 75
	81	82	83	84	85	over 85
Correction Factor						
0.05	1.04	2.07	3.11	4.14	5.18	Use formula shown*
0.10	0.98	1.96	2.94	3.92	4.90	
0.20	0.87	1.74	2.62	3.49	4.36	
0.30	0.76	1.53	2.29	3.05	3.82	

- Interpolation is permissible.

\*Correction Factor = 1.10 x (1 - BF) x (edb - 80).

4. Cooling capacities are gross and do not include deductions for indoor fan motor heat.

# COOLING CAPACITIES (Continued)

## 50ZPM - 60 - English

Temp (F) Air Entering Condenser (Edb)		Evaporator Air - CFM/BPF											
		1650 / 0.177				1800 / 0.199				2000 / 0.224			
		Evaporator Air - EWB (F)											
		57	62	67	72	57	62	67	72	57	62	67	72
75	TC	56,808	57,548	62,701	68,331	57,894	57,971	63,257	68,957	59,191	58,881	63,789	69,604
	SHC	56,031	52,115	43,757	35,183	57,103	53,479	45,270	36,012	58,385	56,003	47,118	37,080
	kW	3.19	3.20	3.23	3.25	3.28	3.29	3.31	3.34	3.44	3.45	3.47	3.50
85	TC	54,738	55,096	60,077	65,544	55,781	55,327	60,544	66,071	57,007	56,990	60,980	66,602
	SHC	53,991	51,071	42,898	34,268	55,020	51,975	44,387	35,098	56,232	56,216	46,252	36,149
	kW	3.53	3.55	3.57	3.60	3.63	3.64	3.66	3.69	3.79	3.79	3.82	3.85
95	TC	52,477	52,574	<b>57,228</b>	62,497	53,455	53,092	57,603	62,947	54,589	54,724	57,969	63,395
	SHC	51,762	49,194	<b>41,909</b>	33,229	52,726	51,165	43,385	34,051	53,848	53,299	45,252	35,105
	kW	3.91	3.93	<b>3.95</b>	3.98	4.00	4.02	4.04	4.07	4.17	4.17	4.20	4.23
105	TC	50,091	50,189	54,168	59,236	50,973	51,003	54,473	59,586	52,012	52,011	54,769	59,938
	SHC	49,408	48,275	40,773	32,106	50,279	50,308	42,241	32,912	51,307	51,306	44,147	33,970
	kW	4.27	4.28	4.31	4.34	4.36	4.36	4.40	4.43	4.53	4.53	4.55	4.59
115	TC	46,835	46,934	50,094	54,856	47,624	47,619	50,323	55,121	48,551	48,545	50,619	55,401
	SHC	46,380	46,372	39,063	30,547	47,162	47,157	40,518	31,330	48,083	48,077	42,624	32,377
	kW	4.69	4.69	4.73	4.77	4.79	4.79	4.82	4.85	4.95	4.95	4.97	5.01
118.4	TC	45,263	45,408	48,213	52,836	46,001	45,996	48,421	53,079	46,879	46,873	48,692	53,326
	SHC	44,648	44,652	37,907	29,563	45,376	45,371	39,299	30,337	46,245	46,240	41,338	31,361
	kW	4.81	4.81	4.85	4.89	4.91	4.91	4.94	4.98	5.07	5.07	5.09	5.13
125	TC	41,121	41,149	43,453	47,642	41,768	41,764	43,648	47,832	42,532	42,527	43,815	48,020
	SHC	41,209	41,205	35,608	27,612	41,857	41,853	37,122	28,360	42,622	42,617	38,798	29,351
	kW	5.19	5.19	5.22	5.27	5.29	5.29	5.31	5.36	5.46	5.46	5.47	5.52

## 50ZPM - 60 - SI

Temp (F) Air Entering Condenser (Edb)		Evaporator Air - (L/s)/BPF											
		779 / 0.177				850 / 0.199				944 / 0.224			
		Evaporator Air - EWB (C)											
		14	17	19	22	14	17	19	22	14	17	19	22
24	TC	16.6	16.9	18.4	20.0	17.0	17.0	18.5	20.2	17.3	17.3	18.7	20.4
	SHC	16.4	15.3	12.8	10.3	16.7	15.7	13.3	10.6	17.1	16.4	13.8	10.9
	kW	3.19	3.20	3.23	3.25	3.28	3.29	3.31	3.34	3.44	3.45	3.47	3.50
29	TC	16.0	16.1	17.6	19.2	16.3	16.2	17.7	19.4	16.7	16.7	17.9	19.5
	SHC	15.8	15.0	12.6	10.0	16.1	15.2	13.0	10.3	16.5	16.5	13.6	10.6
	kW	3.53	3.55	3.57	3.60	3.63	3.64	3.66	3.69	3.79	3.79	3.82	3.85
35	TC	15.4	15.4	<b>16.8</b>	18.3	15.7	15.6	16.9	18.4	16.0	16.0	17.0	18.6
	SHC	15.2	14.4	<b>12.3</b>	9.7	15.5	15.0	12.7	10.0	15.8	15.6	13.3	10.3
	kW	3.91	3.93	<b>3.95</b>	3.98	4.00	4.02	4.04	4.07	4.17	4.17	4.20	4.23
40.6	TC	14.7	14.7	15.9	17.4	14.9	14.9	16.0	17.5	15.2	15.2	16.1	17.6
	SHC	14.5	14.1	11.9	9.4	14.7	14.7	12.4	9.6	15.0	15.0	12.9	10.0
	kW	4.27	4.28	4.31	4.34	4.36	4.36	4.40	4.43	4.53	4.53	4.55	4.59
46	TC	13.7	13.8	14.7	16.1	14.0	14.0	14.7	16.2	14.2	14.2	14.8	16.2
	SHC	13.6	13.6	11.4	9.0	13.8	13.8	11.9	9.2	14.1	14.1	12.5	9.5
	kW	4.69	4.69	4.73	4.77	4.79	4.79	4.82	4.85	4.95	4.95	4.97	5.01
48	TC	13.3	13.3	14.1	15.5	13.5	13.5	14.2	15.6	13.7	13.7	14.3	15.6
	SHC	13.1	13.1	11.1	8.7	13.3	13.3	11.5	8.9	13.6	13.6	12.1	9.2
	kW	4.81	4.81	4.85	4.89	4.91	4.91	4.94	4.98	5.07	5.07	5.09	5.13
52	TC	12.1	12.1	12.7	14.0	12.2	12.2	12.8	14.0	12.5	12.5	12.8	14.1
	SHC	12.1	12.1	10.4	8.1	12.3	12.3	10.9	8.3	12.5	12.5	11.4	8.6
	kW	5.19	5.19	5.22	5.27	5.29	5.29	5.31	5.36	5.46	5.46	5.47	5.52

### LEGEND

BPF — Bypass Factor  
 Edb — Entering Dry-Bulb  
 Ewb — Entering Wet-Bulb  
 SHC — Sensible Heat Capacity (1000 Btuh) - Gross  
**Bold, Italics** - Standard Ratings

Ldb — Leaving Dry-Bulb  
 Lwb — Leaving Wet-Bulb  
 TC — Total Capacity (1000 Btuh) - Gross  
 kW — Compressor Motor Power Input

### Notes:

- Direct interpolation is permissible. Do not extrapolate.
- The following formulas may be used.

$$t_{ldb} = t_{edb} - \frac{\text{sensible capacity (Btuh)}}{1.10 \times \text{cfm}} \quad \quad \quad h_{lwb} = h_{ewb} - \frac{\text{total capacity (Btuh)}}{4.5 \times \text{cfm}}$$

t<sub>lwb</sub> = Wet-bulb temperature corresponding to enthalpy of air leaving evaporator coil (h<sub>lwb</sub>).

h<sub>ewb</sub> = Enthalpy of air entering evaporator coil.

- The SHC is based on 80 F edb temperature of air entering evaporator coil.

- Below 80 F edb, subtract (corr factor x cfm) from SHC.

- Above 80 F edb, add (corr factor x cfm) to SHC.

ENTERING AIR DRY-BULB TEMP (F)						
BF	79	78	77	76	75	under 75
	81	82	83	84	85	over 85
Correction Factor						
0.05	1.04	2.07	3.11	4.14	5.18	Use formula shown*
0.10	0.98	1.96	2.94	3.92	4.90	
0.20	0.87	1.74	2.62	3.49	4.36	
0.30	0.76	1.53	2.29	3.05	3.82	

- Interpolation is permissible.

\*Correction Factor = 1.10 x (1 - BF) x (edb - 80).

- Cooling capacities are gross and do not include deductions for indoor fan motor heat.

# PERFORMANCE AND ACCESSORIES

## Standard Air Flow Rate Delivery Table At Wet Coil - Without Air Filter\*

50ZPM Unit Size	Speed Tap	External Static Pressure (in. wg.)									
		0.1	0.2	0.3	0.4	0.5	0.6	0.7	0.8	0.9	1.0
36	1	1230	1148	1101	1072	1027	978	924	840	805	775
	2	1305	1238	1194	1161	1123	1077	1017	960	910	868
	3	1418	1351	1311	1283	1237	1197	1142	1079	1063	1031
48	1	1678	1690	1646	1608	1555	1521	1479	1445	1398	1357
	2	1729	1740	1702	1670	1626	1585	1548	1508	1467	1424
	3	1955	1976	1936	1904	1855	1820	1787	1748	1704	1666
60	1	1773	1727	1671	1624	1571	1510	1437	1383	1336	1273
	2	1844	1798	1749	1699	1638	1579	1512	1449	1400	1344
	3	2025	1984	1936	1890	1833	1769	1697	1642	1605	1545

## Air Filter Pressure Drop (in. wg.)

Filter Size inch (mm)*	Air Flow Rate (CFM)							
	700	800	900	1000	1100	1200	1300	1400
24x30x1 (610x762x25)	0.03	0.04	0.05	0.06	0.07	0.07	0.08	0.09
24x36x1 (610x914x25)	-	-	-	-	-	0.06	0.07	0.07

\* Throwaway Installed Field Filter

## Air Filter Pressure Drop (in. wg.)

Filter Size inch (mm)*	Air Flow Rate (CFM)						
	1500	1600	1700	1800	1900	2000	2100
24x30x1 (610x762x25)	0.10	-	-	-	-	-	-
24x36x1 (610x914x25)	0.08	0.09	0.09	0.1	0.11	0.12	0.13

\* Throwaway Installed Field Filter

## Accessory Electric Heater Pressure Drop (in. wg.)

Heater kW	Air Flow Rate (CFM)						
	800	1000	1200	1400	1600	1800	2000
4.6-18.4	0.033	0.037	0.042	0.047	0.052	0.060	0.067

## Accessory Electric Heaters (230-1Phz-50Hz)

Catalogue Ordering Number*	Application Capacity (KW)	Used With Sizes				
		Circuit Breaker	Stages	36	48	60
CPHEATER125A02	4.6	No	1	√	√	√
CPHEATER126A02	4.6	Yes	1	√	√	√
CPHEATER127A02	6.9	No	2	√	√	√
CPHEATER128A02	6.9	Yes	2	√	√	√
CPHEATER129A02	9.2	No	2	√	√	
CPHEATER130A02	9.2	Yes	2	√	√	√
CPHEATER131A02	13.8	Yes	2	√	√	√
CPHEATER132A02	18.4	Yes	2		√	√

\* Note:- All nominal Heater capacity are @240V, Application Capacity calculated on 230V

# ELECTRICAL DATA

50ZPM - Application			Compressor		OFM		IFM		Electric Heater		MCA	MOCP
Unit Size	Power Supply V / Ph / Hz	Min - Max Voltage	RLA	LRA	HP	FLA	HP	FLA	Appl. KW	FLA		
36	400/3/50	360 - 440	4.5	35.0	1/3	1.4	1/2	4.1	-	-	11.1	15
									4.59	19.9	25.0	30
									6.88	29.9	35.0	40
									9.18	39.9	45.0	50
									13.80	60.0	65.1	70
48			7.8	51.5	1/3	1.4	3/4	6.0	-	-	17.2	20
									4.59	19.9	27.4	30
									6.88	29.9	37.4	40
									9.18	39.9	47.4	50
									13.80	60.0	67.5	70
60	8.5	67.1	1/3	1.4	1	7.6	-	-	19.6	25		
							4.59	19.9	29.4	35		
							6.88	29.9	39.4	45		
							9.18	39.9	49.4	60		
							13.80	60.0	69.5	80		

### Legend and Notes for Electrical Data Table

**FLA** - Full Load Amps

**IFM** - Indoor (Evaporator) Fan Motor

**LRA** - Locked Rotor Amps

**MCA** - Minimum Circuit Amps

**OFM** - Outdoor (Condenser) Fan Motor

**RLA** - Rated Load Amps

**APP** - Application power at rated power supply voltage

**MOCP** - Maximum Overcurrent Protection

### Unbalanced 3-Phase Supply Voltage

Never operate a motor where phase imbalance in supply voltage is greater than 2%.

Use the following formula to determine the percentage of voltage imbalance

$$= 100 \times \frac{\text{Maximum Deviation From Average Voltage}}{\text{Average Voltage}}$$

Example: Supply Voltage is 400V - 3ph - 50Hz

AB = 392v	Average Voltage = $\frac{392 + 404 + 395}{3}$
BC = 404v	
AC = 395v	$= \frac{1191}{3} = 397V$

This amount of phase imbalance is satisfactory as it is below the maximum allowable 2%

Determine maximum deviation from average voltage.

(AB) 397 - 392 = 5v

(BC) 404 - 397 = 7v

(AC) 457 - 397 = 2v

Maximum Deviation is 7v.

Determine Percentage Voltage Imbalance.

$$\% \text{ Voltage Imbalance} = 100 \times \frac{7}{397} = 1.76\%$$

**IMPORTANT:** If the supply voltage phase imbalance is more than 2% contact your local electric utility company

# TYPICAL WIRING SCHEMATIC – 50ZPM – 400V-50Hz

## CONNECTION WIRING DIAGRAM

DANGER: ELECTRICAL SHOCK HAZARD DISCONNECT POWER BEFORE SERVICING

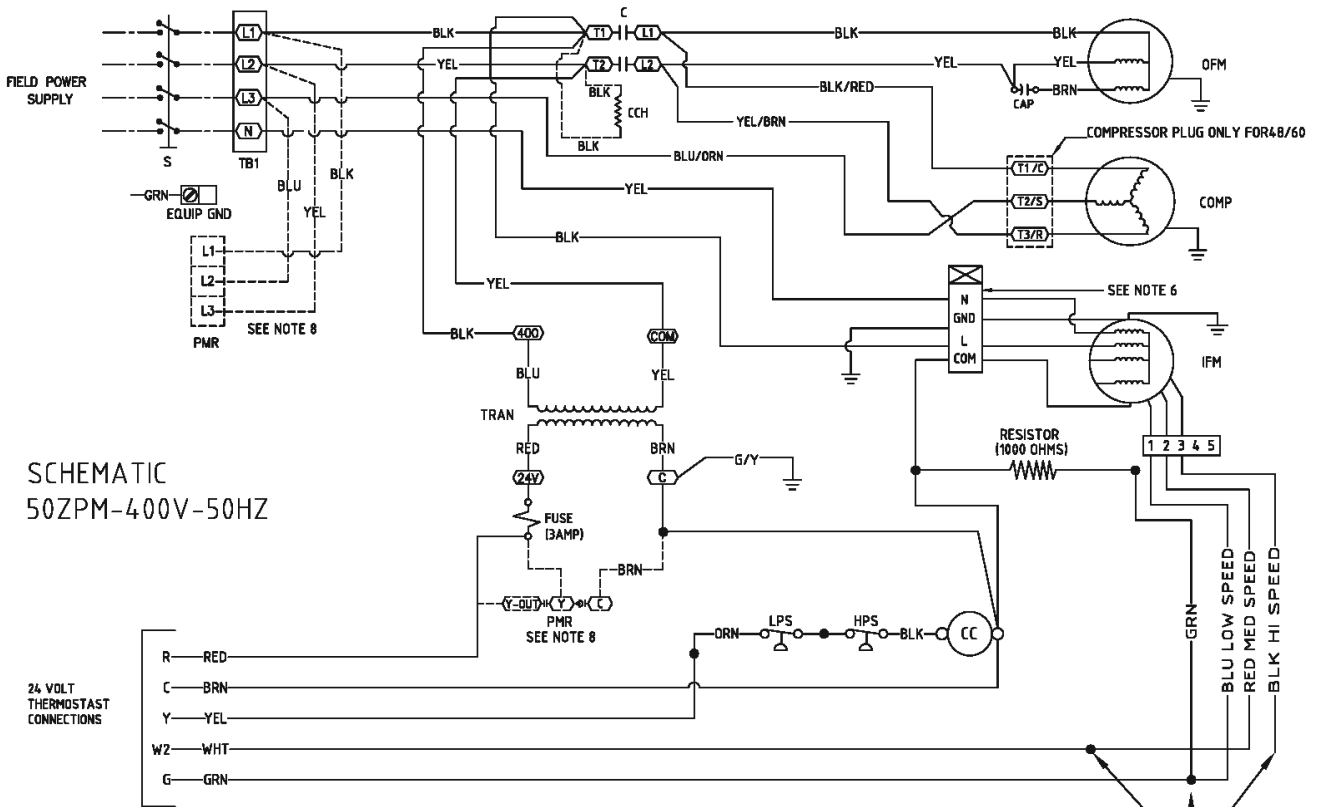

SCHEMATIC  
50ZPM-400V-50HZ

24 VOLT  
THERMOSTAT  
CONNECTIONS

ACCESSORY  
ELECTRIC HEAT  
24 VOLT  
THERMOSTAT  
CONNECTION  
(SEE NOTE 7)

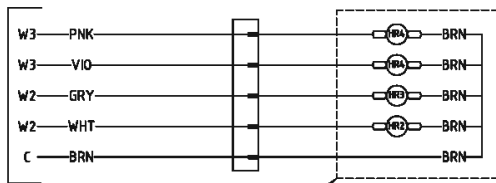

ACCESSORY ELECTRIC HEAT  
(24 VOLT HEATER CONNECTIONS)

### COLOR CODE

BLK	BLACK
BLU	BLUE
BRN	BROWN
GRN	GREEN
GRY	GRAY
G/Y	GREE/YELLOW
ORN	ORANGE
PNK	PINK
RED	RED
VIO	VIOLET
WHT	WHITE
YEL	YELLOW

SEE NOTE 5

### FAN SEQUENCE

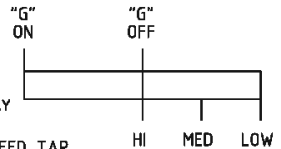

### LEGEND

	FIELD SPICE
	TERMINAL MARKED
	TERMINAL UNMARKED
	SPLICE
	FACTORY WIRING
	FIELD CONTROL WIRING
	FIELD POWER WIRING
	ACCESSORY OR OPTIONAL WIRING
C	CONTACTOR
CAP	CAPACITOR
CC	CONTACTOR COIL
COMP	COMPRESSOR MOTOR
GND	GROUND
HR	HEATER RELAY
IFM	INDOOR FAN MOTOR
HPS	HIGH PRESSURE SWITCH
LPS	LOW PRESSURE SWITCH
OFM	OUTDOOR MOTOR
PMR	PHASE MONITOR RELAY
S	MAIN SWITCH
TRAN	TRANSFORMER
TB	TERMINAL BOARD
CCH	CRANK CASE HEATER

UNIT COMPONENT ARRANGEMENT:

CONTROL BOX AREA

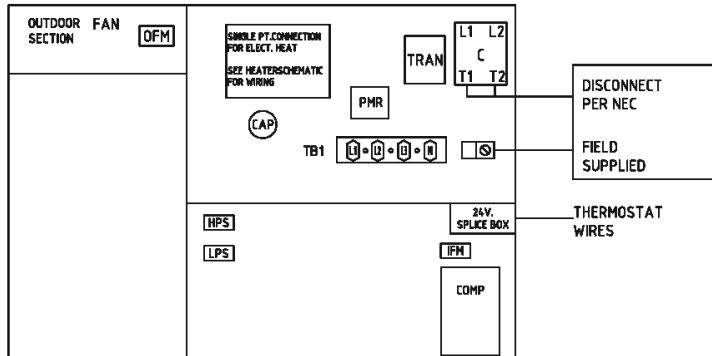

### NOTES:

- IF ANY OF THE ORIGINAL WIRES FURNISHED ARE REPLACED, IT MUST BE REPLACED WITH THE SAME TYPE OF WIRE (105°C OR IT'S EQUIVALENT).
- USE CONDUCTORS SUITABLE FOR AT LEAST 105°C FOR FIELD INSTALLATION.
- FACTORY WIRING FOR SPEED SELECTOR PLUG CHANGING OF SPEED TAPS MAY BE REQUIRED WHEN USING FIELD INSTALLED ELECTRIC HEATERS, CONSULT INSTALLATION INSTRUCTIONS TO DETERMINE CORRECT SPEED TAP SETTING.
- "DO NOT DISCONNECT PLUG UNDER LOAD."
- MULTI-STAGE HEATER SHOWN. SINGLE STAGE HEATERS HAVE WHITE AND BROWN WIRES ONLY.
- FUSE MANUFACTURED BY LITTELFUSE, P/N 257003.
- PHASE MONITOR USED ONLY FOR 50ZPM 48/60.

# TYPICAL INSTALLATION

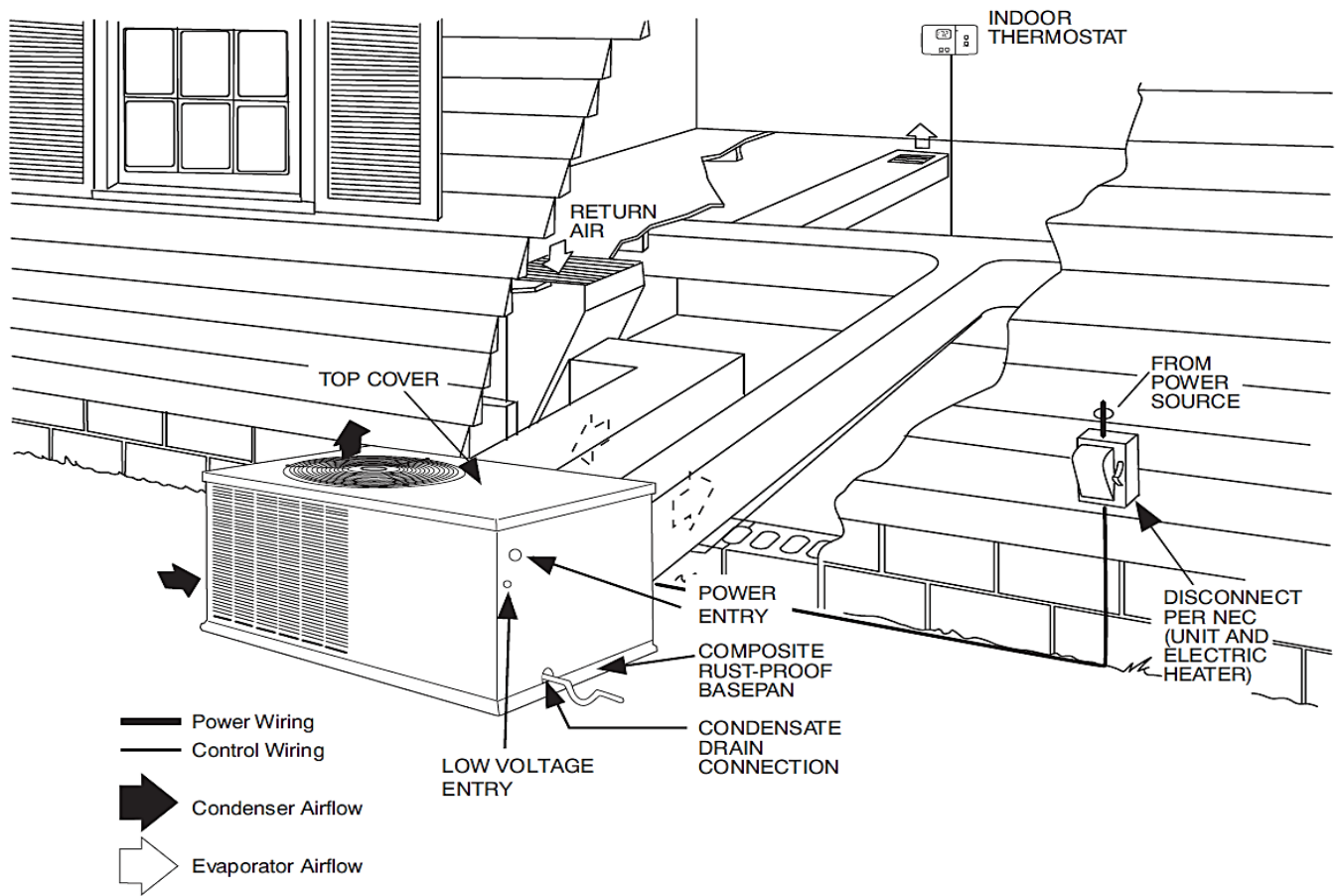

## LEGEND:

NEC - National Electrical Code

## NOTES:

1. All wiring must comply with the applicable local and national codes.
2. Wiring shown are general points-of-connection guides only and are not intended for, or to include all details for a specific installation.

## APPLICATION DATA

Condensate trap — A 2- in. (51 mm) condensate trap must be field supplied.

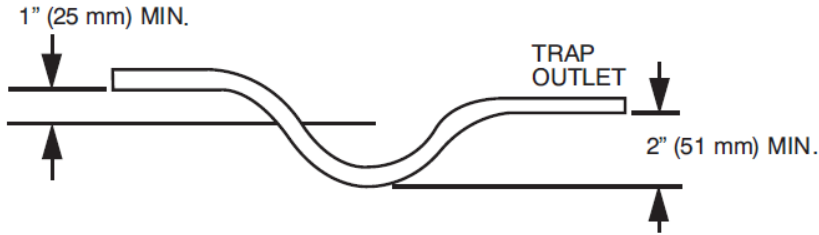

**Maximum cooling airflow** — To minimize the possibility of condensate blow-off from the evaporator, airflow through the units should not exceed 450 CFM/ton.

**Minimum cooling airflow** — The minimum cooling airflow is 350 cfm/ton.

**Minimum cooling operating outdoor air temperature** — All standard units have a minimum ambient operating temperature of 40°F (4.4°C).

**Maximum operating outdoor air temperature** — Maximum outdoor operating air temperature for cooling is 125°F (52°C).

## OPERATING SEQUENCE

### Cooling Operation

With a call for cooling (Y/G), the contactor is energized which brings on the compressor and outdoor fan. The indoor fan is also energized. When the cooling demand is met, Y and G are de-energized shutting off the contactor. The indoor fan stops after a 60 second delay.

### Heating Operation

With a call for heating (W2), the auxiliary or electric heat energizes along with the indoor blower. In case of staged heating, W3 is energized if the demand is not met. The highest airflow selected is run while the electric heat is in operation. When heating demand is met, W3 and W2 sequentially de-energize shutting off the indoor fan and the electric heater.

### Continuous Fan (Thermostat Feature)

With the continuous indoor fan option selected on the thermostat, G is continuously energized keeping the indoor fan running at all times.



# GUIDE SPECIFICATIONS – 50ZPM

## Single- Packaged Air Conditioner System With R- 410A Refrigerant HVAC Guide Specifications Size Range: 3.0 to 5.0 Nominal Tons



### System Description

Small-Capacity Self-Contained Air Conditioners (50ZPM), electrically controlled, heating and cooling unit utilizing hermetic reciprocating or scroll compressor for cooling duty and electric for heating duty.

### Quality Assurance

- A. Unit shall be designed in accordance and conform to ASHRAE 15, 2001, UL Standard 1995.
- B. Unit shall be rated in accordance with AHRI Standards 340/360.
- C. Unit shall achieve ASHRAE 90.1 minimum efficiency requirements (2010 version).
- D. Insulation and adhesive shall meet NFPA 90A requirements for flame spread and smoke generation.
- E. Unit casing shall be capable of withstanding 500-hour salt spray exposure per ASTM B117 (scribed specimen).
- F. Unit shall be designed in accordance with ISO 9001:2008, and shall be manufactured in a registered ISO 9001:2008 facility.
- G. Unit shall be subjected to a completely automated run test on the assembly line. The data for each unit will be stored at the factory, and must be available upon request.
- H. All wiring shall be in accordance with NEC.
- I. Unit shall have a sloped drain pan that conforms to ASHRAE Standard 62.2.

### Delivery, Storage, And Handling

- A. Unit shall be stored and handled per manufacturer's recommendations.
- B. Unit shall only be stored or positioned in the upright position.

### Product General

- A. Factory assembled, single-piece heating and cooling rooftop unit. Contained within the unit enclosure shall be all factory wiring, piping, controls, and special features required prior to field start-up.
- B. Unit shall use environmentally safe, Puron refrigerant.
- C. Unit shall be installed in accordance with the manufacturer's instructions.
- D. Unit must be selected and installed in compliance with local, state, and federal codes.
- E. Interior cabinet surfaces shall be insulated with closed cell foam minimum ½ -in. thick, minimum density 3.1lb/ft<sup>3</sup>.

### Unit Cabinet

- A. Unit cabinet shall be constructed of galvanized steel, and shall be bonderized and coated with a pre-painted baked enamel finish on all externally exposed surfaces.
- B. Unit cabinet exterior paint shall be: film thickness, (dry) 76mm minimum, gloss (per ASTM D523, 60°F): 60, Hardness: H-2H Pencil hardness, Base-pan shall be made of single piece non-corrosive, composite material. Evaporator- fan compartment interior cabinet surfaces shall be insulated with a minimum 1/2- in. (12.7 mm) thick, coated on the air side with aluminum foil.
- C. Top panel: Shall be a two piece top panel.
- D. Electrical Connections: All unit power wiring shall enter unit cabinet at a single, factory-prepared, knock out location.
- E. Component access panels shall be easily removable for servicing. Service panels shall have molded composite handles UV modified, composite, permanently attached, and recessed into the panel.

### Coils

Standard Aluminum fin-Copper Tube Coils:

- A. Standard evaporator and condenser coils shall have aluminum lanced plate fins mechanically bonded to seam- less internally grooved copper tubes with all joints brazed.
- B. Evaporator coils shall be leak tested to 150 psig, pressure tested to 350 psig, and qualified to UL 1995 burst test at 1775 psig.
- C. Condenser coils shall be leak tested to 150 psig, pressure tested to 450 psig, and qualified to UL 1995 burst test at 1980 psig.

Optional Pre-coated aluminum-fin condenser coils:

- A. Shall have a durable epoxy-phenolic coating to provide protection in mildly corrosive coastal environments.
- B. Coating shall be applied to the aluminum fin stock prior to the fin stamping process to create an inert barrier between the aluminum fin and copper tube.
- C. Epoxy-phenolic barrier shall minimize galvanic action between dissimilar metals.

Optional Copper-fin evaporator and condenser coils: Shall be constructed of copper fins mechanically bonded to copper tubes.

**Compressor**

Compressor shall be fully hermetic type with external vibration isolation.

**Condenser Section**

Condenser fan shall be of the direct- driven propeller type blades, riveted to corrosion-resistant spiders, and shall be dynamically balanced and discharge air vertically upwards. Condenser coils shall have aluminum- plate fins mechanically bonded to copper tubes with all joints brazed. Tube sheet openings shall be belled to prevent tube wear.

**Evaporator Section**

Fan shall be multi- speed with direct drive motor. Fan wheel shall be made from steel, double-inlet type with forward-curved blades with a corrosion-resistant finish and dynamically balanced. Evaporator coils shall have aluminum-plate fins mechanically bonded to copper tubes with all joints brazed. Tube sheet openings shall be belled to prevent tube wear.

**Motors**

Compressor motors shall be of the refrigerant cooled type with line break thermal and current overload protection. All fan motors shall have permanently lubricated bearings, and inherent automatic reset thermal overload protection. Condenser fan motor shall be totally enclosed.

**Refrigerant System**

Refrigerant system shall include fixed orifice or TXV metering system with filter drier. Service gauge connections on both suction and discharge lines.

**Controls**

Unit shall be complete with self- contained low voltage control circuit.

**Electric and Electronic Control System for HVAC**

- A. Shall be complete with self-contained low-voltage control circuit protected by a resettable circuit breaker on the 24V transformer side. Shall utilize color-coded wiring.
- B. Unit shall include a screw terminal connection board for connection of control wiring.
- C. Internal compressor over-temperature, over current.
- D. Low pressure switch.
- E. High pressure switch.
- F. Internal automatic reset, motor thermal overload protector.

**Electrical Requirements**

Main power supply voltage, phase, and frequency must match those required by the manufacturer.

**Accessories**

Field-supplied, field-installed accessories shall include thermostats, electric heaters with single-point connection and return air filters.

## NOTES

